

## VALET VBS MOTOR

**Model: 117123-00**  
**Part No 70473**

### DESCRIPTION

- Three stage
- 240 volt
- 5.7"/145mm diameter
- Double ball bearings
- Single speed
- Tangential bypass discharge
- Aluminum fan end bracket
- Aluminum commutator bracket

### DESIGN APPLICATION

- Equipment operating in environments requiring separation of working air from motor ventilating air.
- Designed to handle clean, dry, filtered air only.

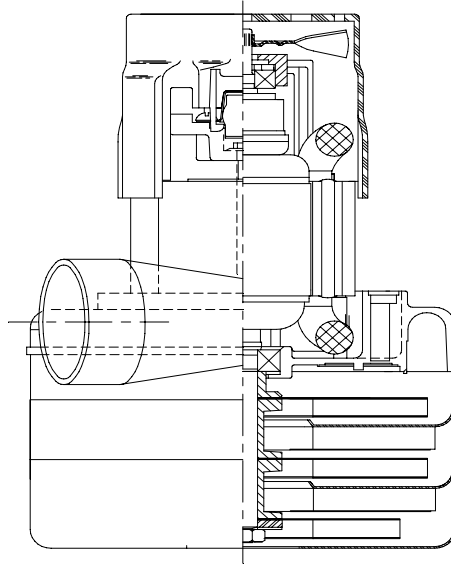

### SPECIAL FEATURES

- Suitable for 240 volt AC operation, 50/60 Hz.
- UL recognized, category PRGY2 (E47185)
- 10mm shaft and bearing system
- Provision for grounding.
- Skeleton-frame design
- Aluminum fan end bracket designed to dampen vibration and improve durability.
- The Lamb Electric vacuum motor line offers a wide range of performance levels to meet design needs

**\*Model 117123-13 features patented air seal bearing protection, U.S. Patent #4,088,424 and epoxy painted fan case**

### TYPICAL MOTOR PERFORMANCE.\*

(At 240 volts, 60Hz, test data is corrected to standard conditions of 29.92 Hg, 68° F.)

ASTM DATA

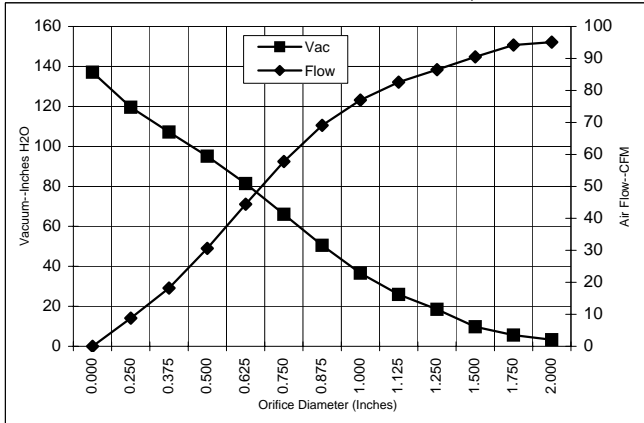

Orifice (Inches)	Amps	Watts (In)	RPM	Vac (In.H <sub>2</sub> O)	Flow (CFM)	Air Watts
2.000	6.8	1533	20420	3.3	95.1	37
1.750	6.8	1530	20350	5.6	94.2	62
1.500	6.9	1534	20350	9.8	90.5	104
1.250	6.9	1544	20230	18.5	86.5	189
1.125	7.0	1559	20180	25.9	82.6	252
1.000	7.0	1566	20080	36.6	77.0	331
0.875	7.0	1566	20080	50.5	69.1	410
0.750	6.8	1516	20440	66.0	57.8	448
0.625	6.4	1430	20960	81.4	44.4	425
0.500	5.9	1315	21850	95.1	30.6	342
0.375	5.3	1186	22860	107.2	18.2	229
0.250	4.7	1067	24210	119.6	8.8	124
0.000	4.2	951	25790	137.1	0.0	0

METRIC DATA

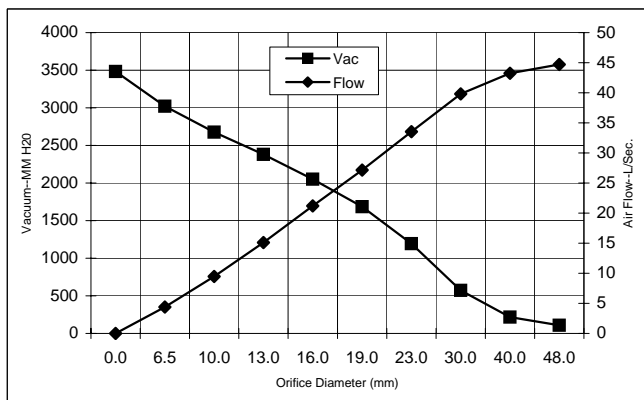

Orifice (mm)	Amps	Watts (In)	RPM	Vac (mm H <sub>2</sub> O)	Flow (L/Sec)	Air Watts
48.0	6.8	1532	20389	110	44.7	48
40.0	6.9	1533	20350	217	43.2	91
30.0	7.0	1552	20203	573	39.8	224
23.0	7.0	1566	20080	1194	33.5	390
19.0	6.8	1514	20450	1684	27.2	448
16.0	6.4	1433	20939	2052	21.2	426
13.0	6.0	1327	21761	2381	15.1	350
10.0	5.4	1205	22709	2677	9.5	246
6.5	4.7	1073	24143	3022	4.4	129
0.0	4.2	951	25790	3482	0.0	0

Note: Metric performance data is calculated from the ASTM data above.

\* Data represents performance of a typical motor sampled from a large production quantity. Individual motor data may vary due to normal manufacturing variations.

<b>Test Specs:</b>	<b>240 volts</b>	<b>Minimum Sealed Vacuum:</b>	<b>132.0"</b>	<b>ORIFICE:</b>	<b>7/8 "</b>	<b>Minimum Vacuum:</b>	<b>44.0"</b>	<b>Maximum Watts:</b>	<b>1760</b>
--------------------	------------------	-------------------------------	---------------	-----------------	--------------	------------------------	--------------	-----------------------	-------------

